

ECO - Proportional Valve

Installation Instructions (Including Operating Instructions)

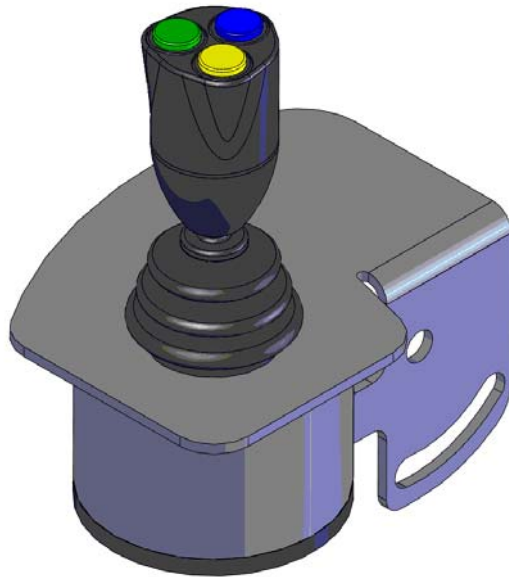

+



Installation Instructions ECO - Proportional Valve

Before starting the installation of the system, please ensure that all parts required according to the parts list are available.

Important: No damages are to incur during transport, installation or use as these may lead to malfunctions.

Mounting of the complete unit may only be effected when the tractor is switched off. After the mounting is done, you need to read the operation instructions as you need to do some basic adjustments.

Table of Contents:

1. Hydraulics	3
Installation of the proportional valve:	3
Hydraulic connection of the lifting arm:	3
Hydraulic connection on the tractor:	4
Nimco-Valve:	4
Walvoil-Valve:	4
Installation of the pressure reservoir:	5
Nimco-Valve:	5
Walvoil-Valve:	5
2. Electronics	6
Installation of the safety button:	6
Installation of the joystick:	6
Installation of the job calculator:	7
Installation of the cover plate:	7
Electrical connection:	7
Walvoil-Valve:	8
Nimco valves:	8
joystick press buttons and socket cable plan	11
Connection diode for Robust FS / FZ with 4th control circuit:	12
Software version 3.5 (green point outside on the housing)	13
Calibration of the joystick:	13
Set valve type:	14
Operating instructions	15
Maintenance notes:	17
Fault finding:	18
Service-LED's:	20

1. Hydraulics

Installation of the proportional valve:

The proportional valve is not screwed onto the Hydrofix but to the valve itself.

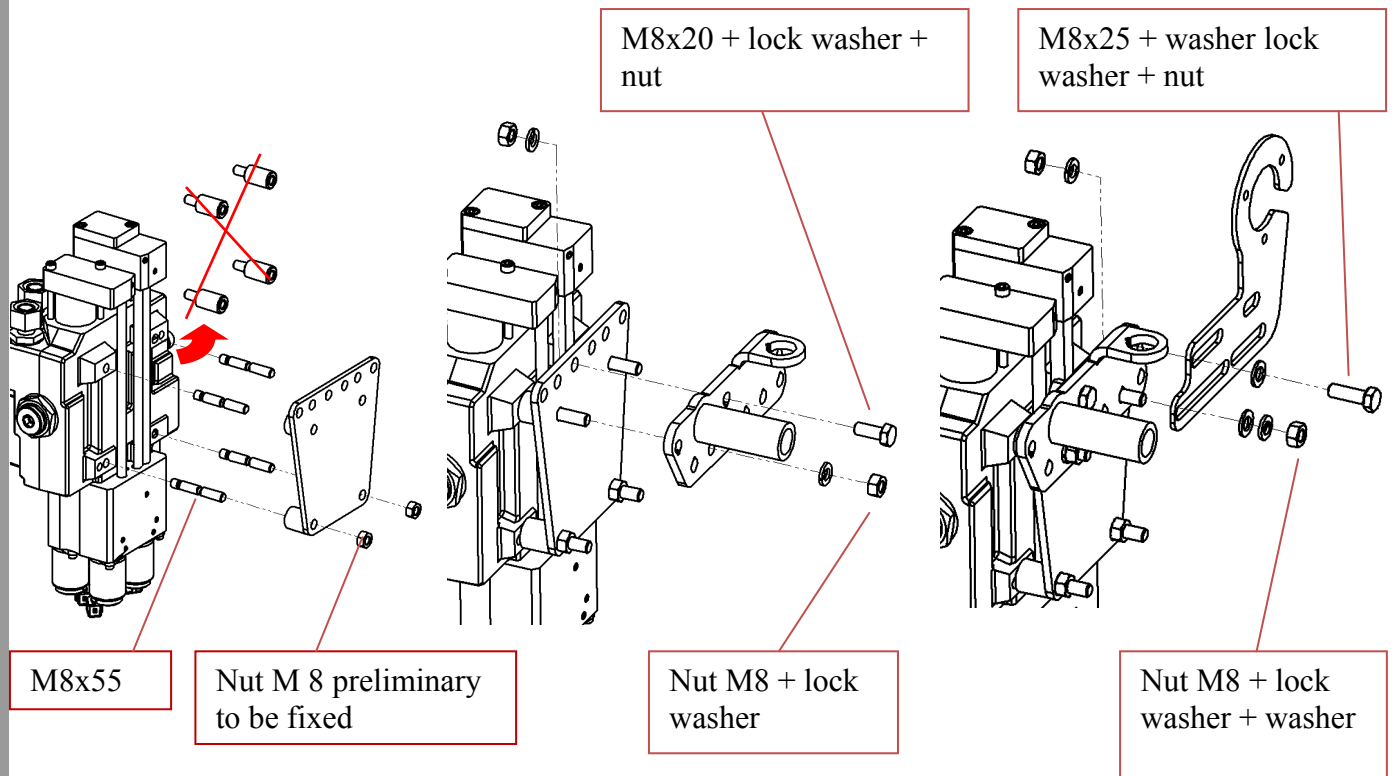

Hydraulic connection of the lifting arm:

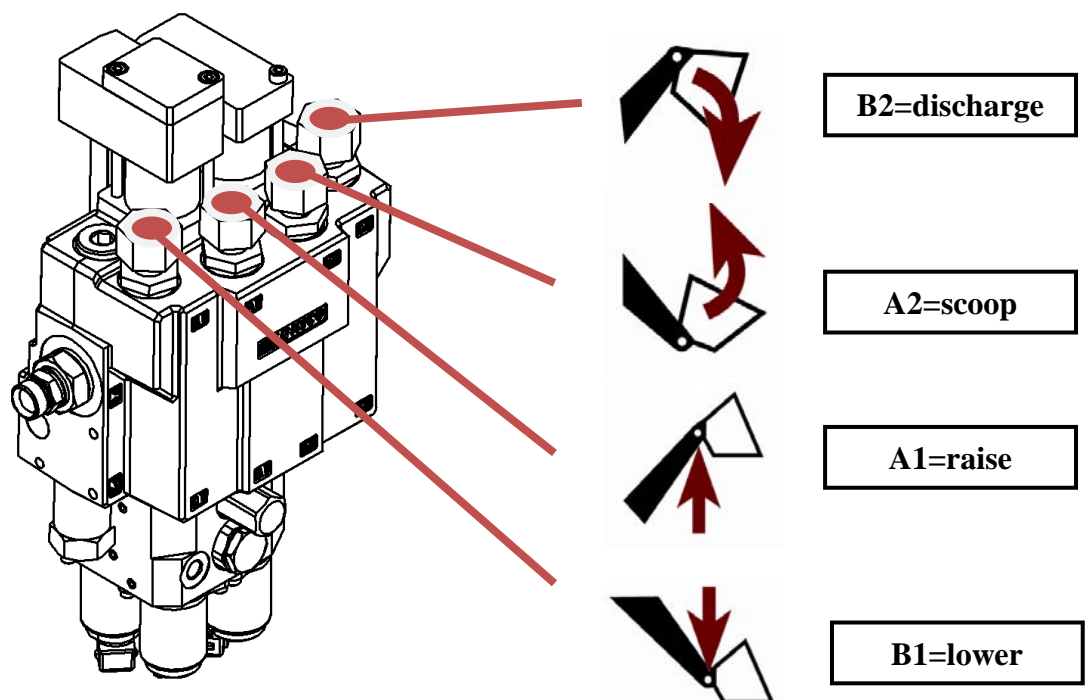

Hydraulic connection on the tractor:

The installation of the hydraulics is carried out according to the set of pictures, which is included in the delivery (tractor specific). The relevant valve is connected as described below:

Nimco-Valve:

EPCV 452 LS-LSP:

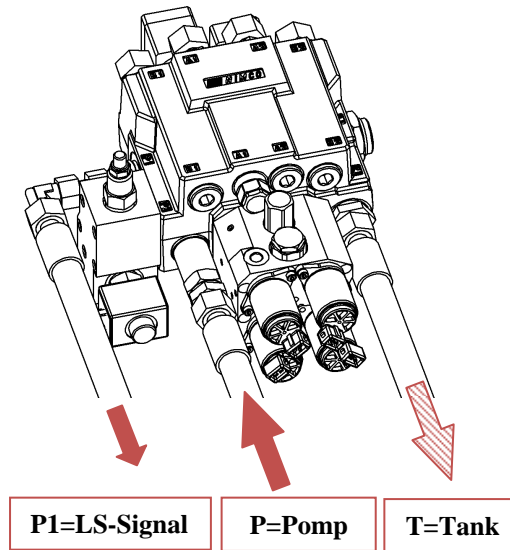

Walvoil-Valve:

DLM 142/2 APF LS:

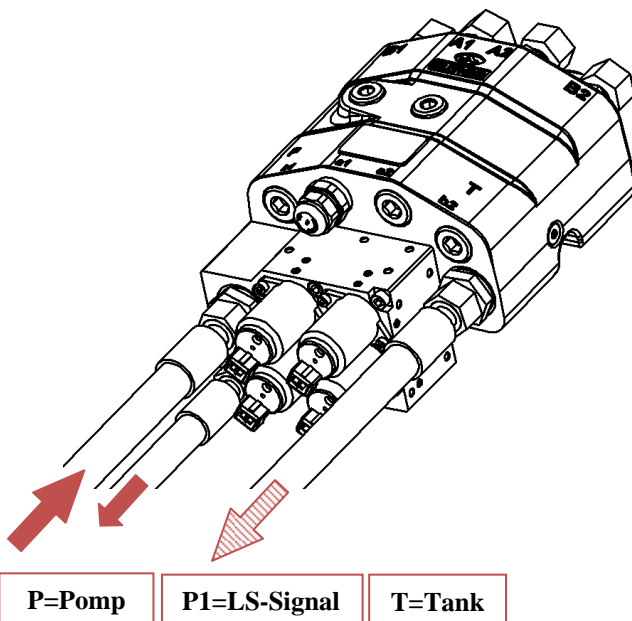

SDM 143/2-PF OC:

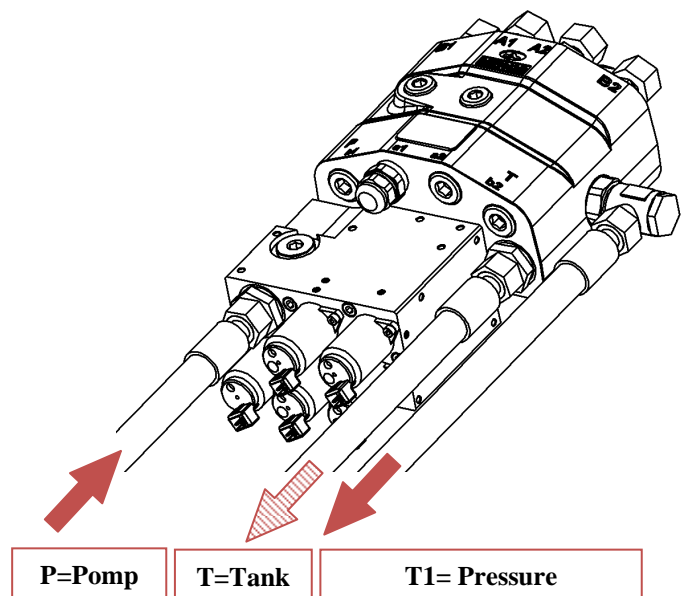

DLM 142/2 APF LS-LSP:

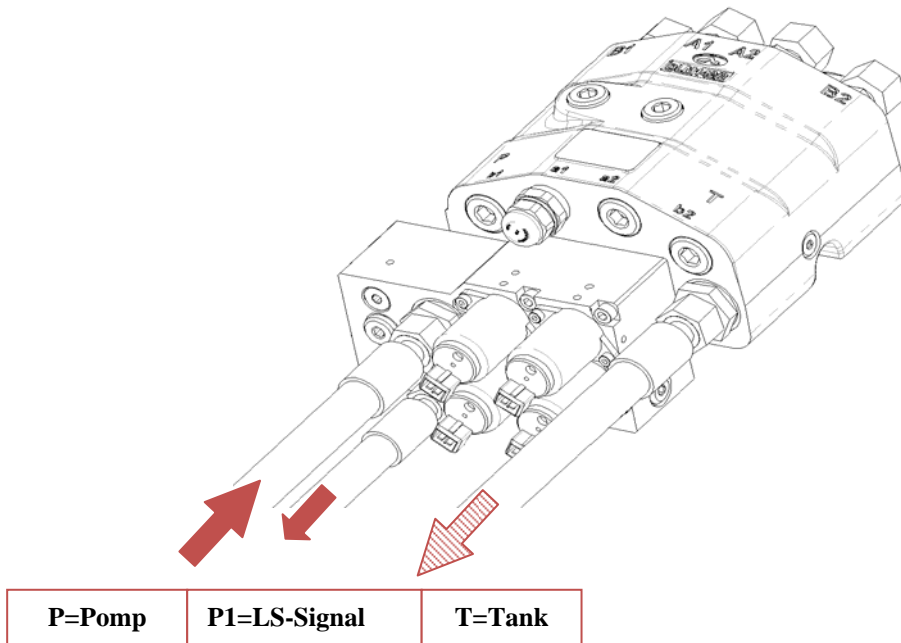

Installation of the pressure reservoir:

The pressure reservoir is attached to the valve at "Point X" according to the following picture.

Nimco-Valve:

Walvoil-Valve:

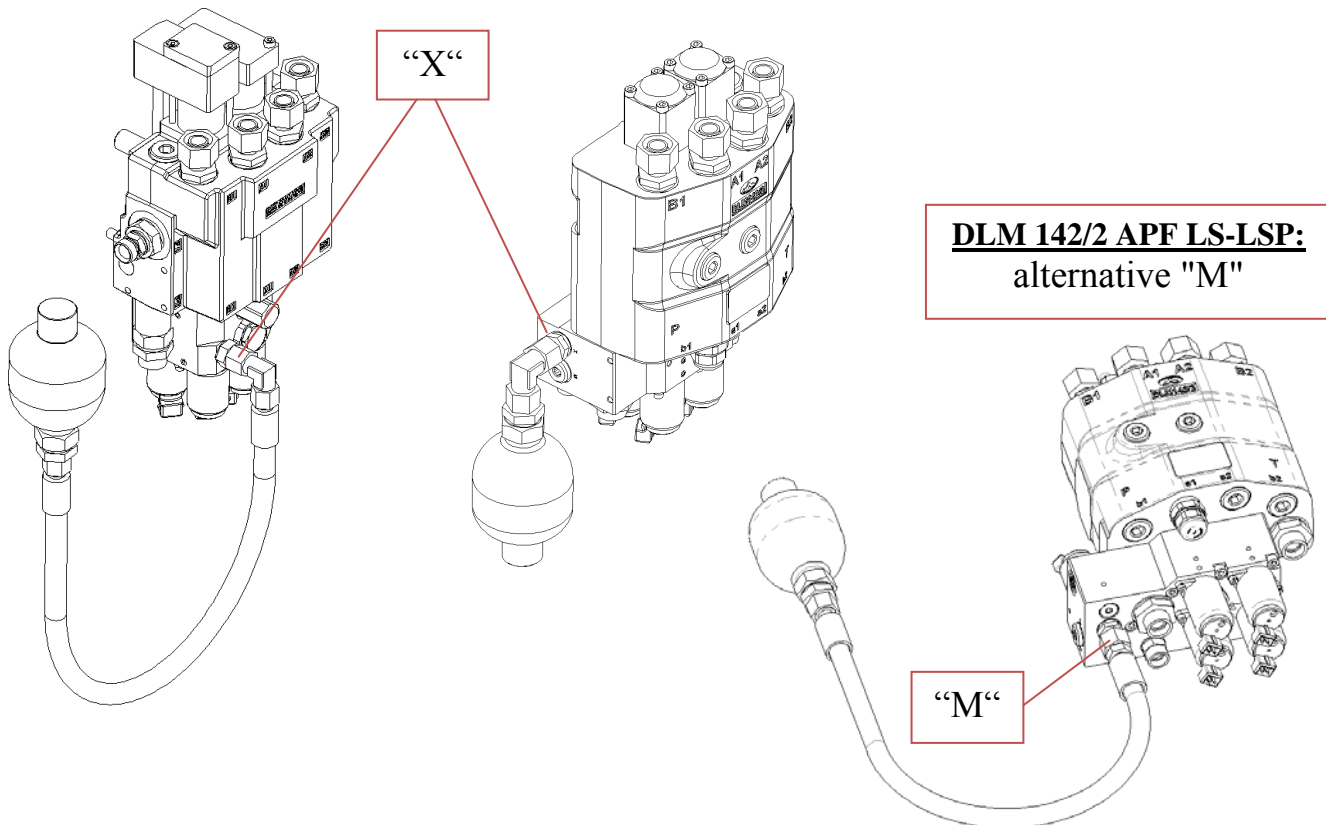

2. Electronics

Installation of the safety button:

The safety button should be positioned at a fairly accessible place on the dashboard or the side panel.

Attention: Do not damage supporting cabin parts

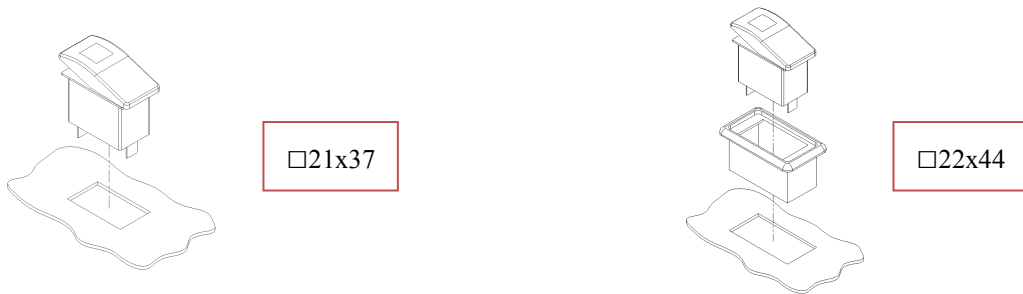

Installation of the joystick:

The additional holder, which may be included, is not required for a control lever activated by Bowden wire.

Attention: If the tractor is equipped with a multifunctional arm rest, the joystick has to be attached individually unless a special holder is also included in the delivery.

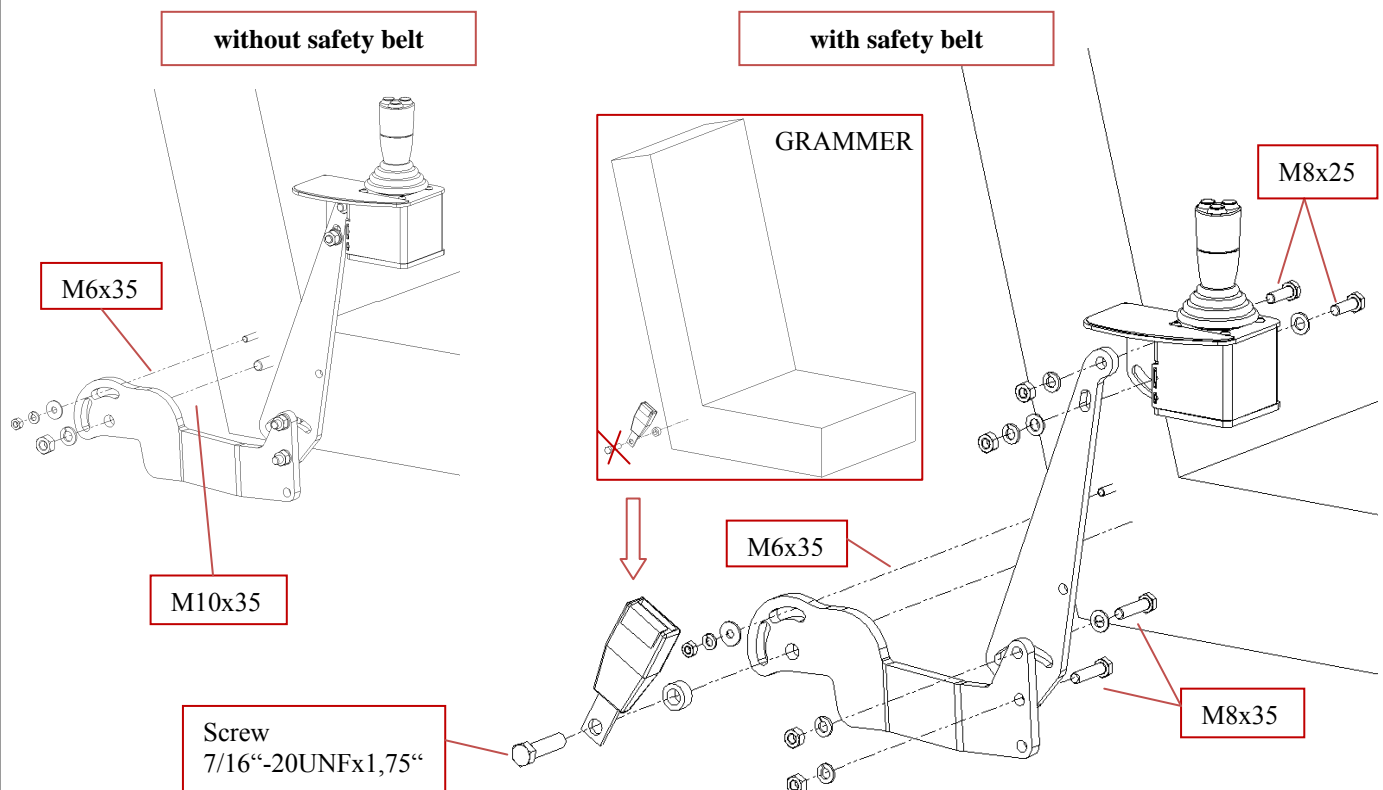

The plastic cover may have to be omitted.

Installation of the job calculator:

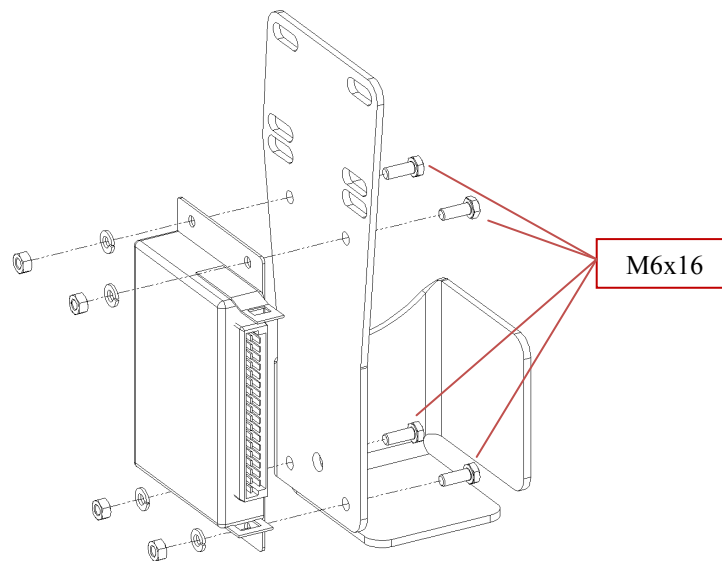

Installation of the cover plate:

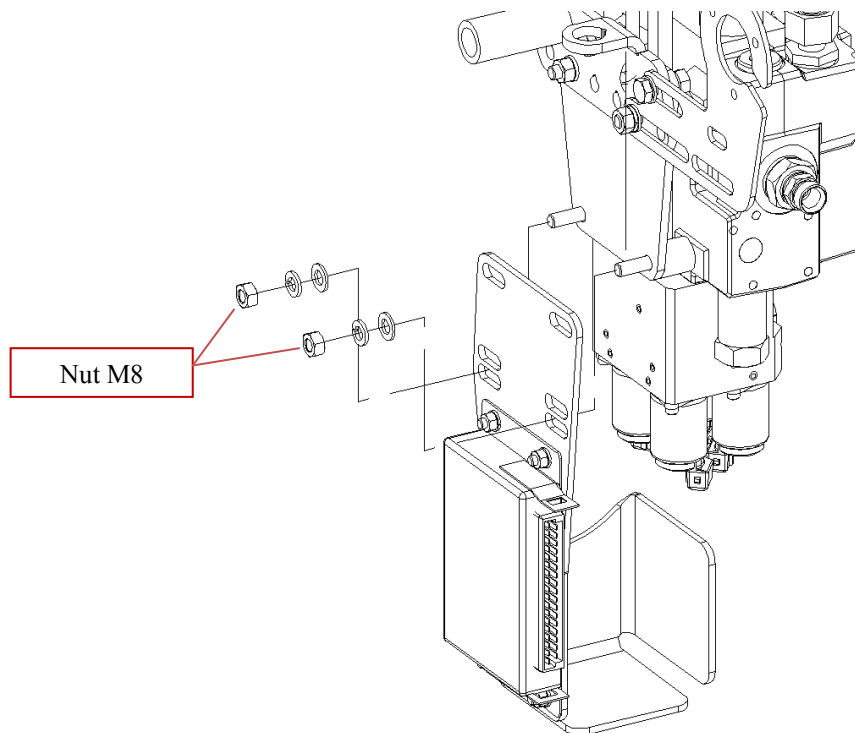

Install the cover plate as high as possible!

Electrical connection:

- Connect the periphery cable (Art.-no. 426C6000) to the job calculator (Art.-No. 426C2000)
- The four marked cables (A1, A2, B1, B2) must be connected correctly according to the following diagram.
Attention: If connected incorrectly, malfunctions may occur.

Walvoil-Valve:

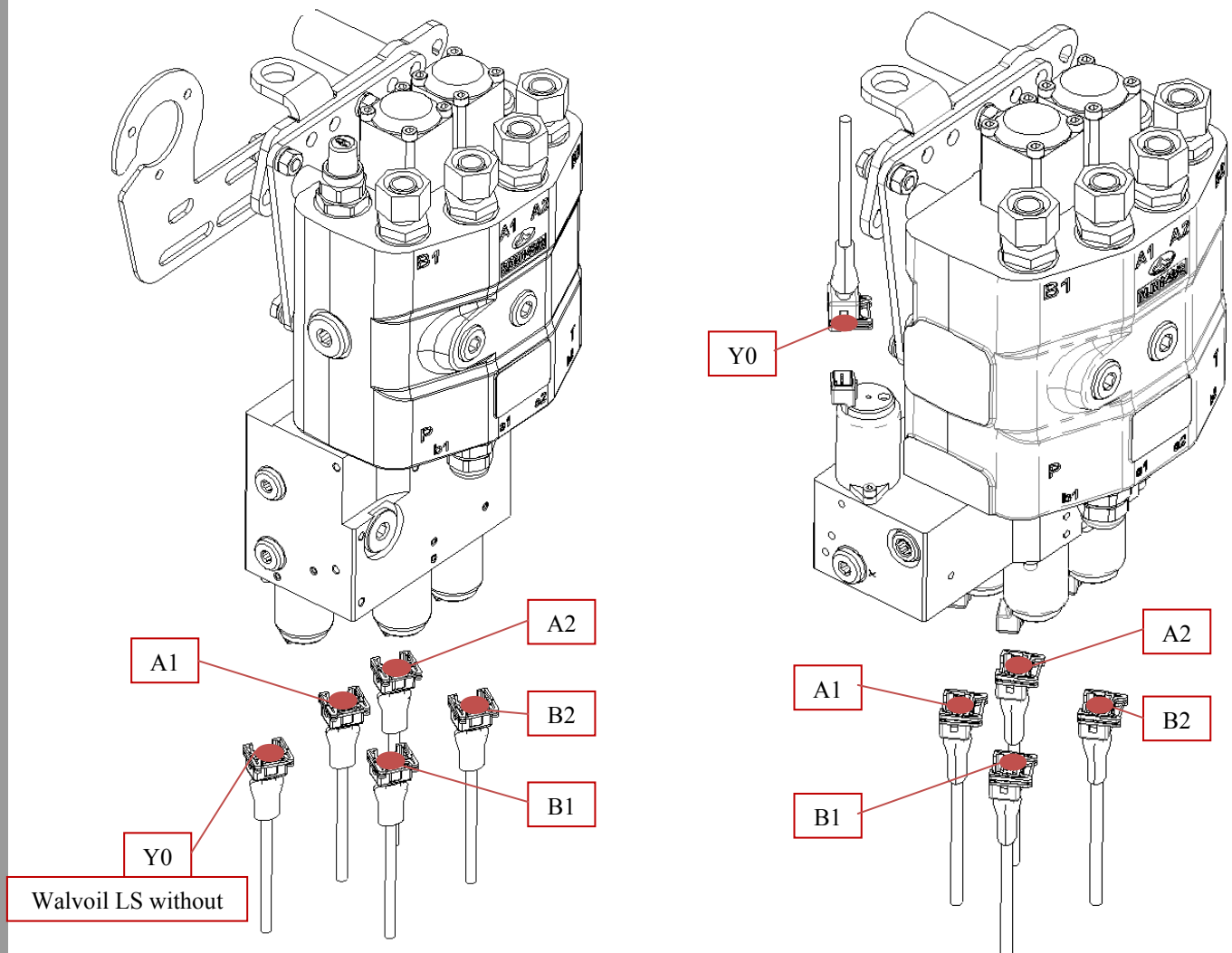

Nimco valves:

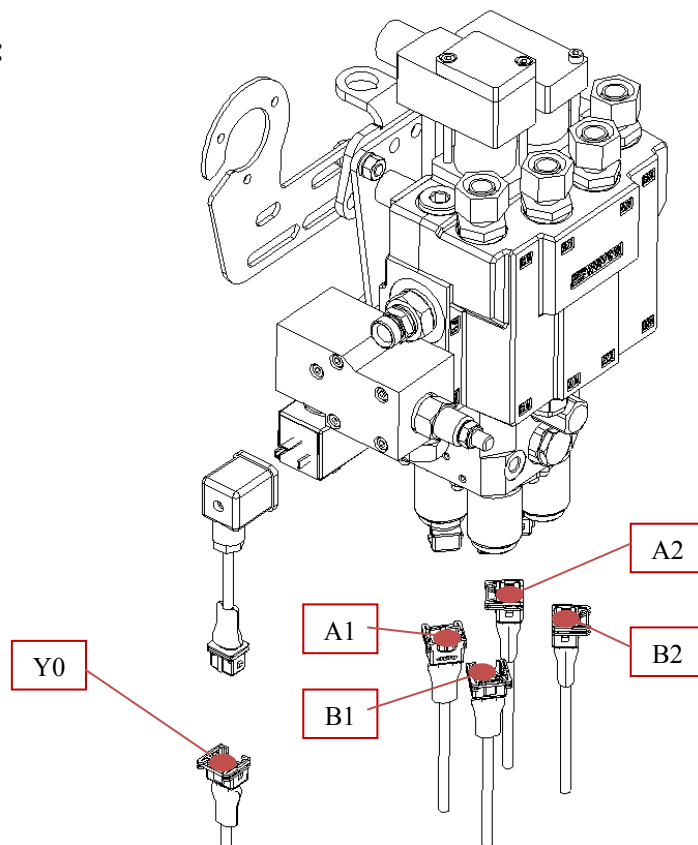

- The cable with single plug base will be connected to the safety button. For this, a feed through has to be found - depending on the tractor type at a suitable position, so that the cable will be led into the cabin.
- The cable with the 9-pin socket should be connected to the joystick. For this, a feed-through (\varnothing 35mm) must be found first at a position convenient for the type of tractor in order to feed the cable into the cabin.

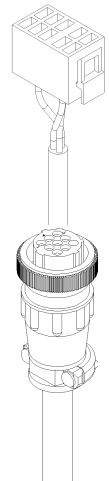

- The cable with the 7-pin socket should be screwed with the socket to the clutch support.

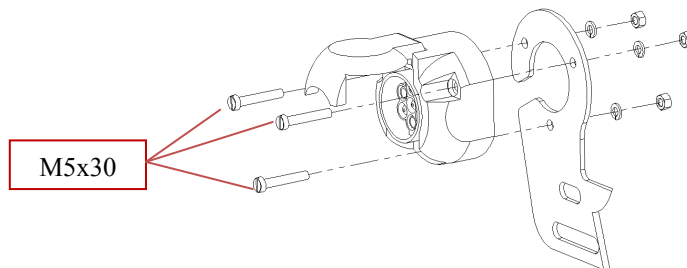

- The cable with the 5A fuse and the name “+12V” must be connected to a connectable and disconnectable power supply via an ignition lock via the enclosed line connector. For more current tractors, which are equipped with a power supply socket according to DIN 9680 (3-pin socket) this is fairly simple.

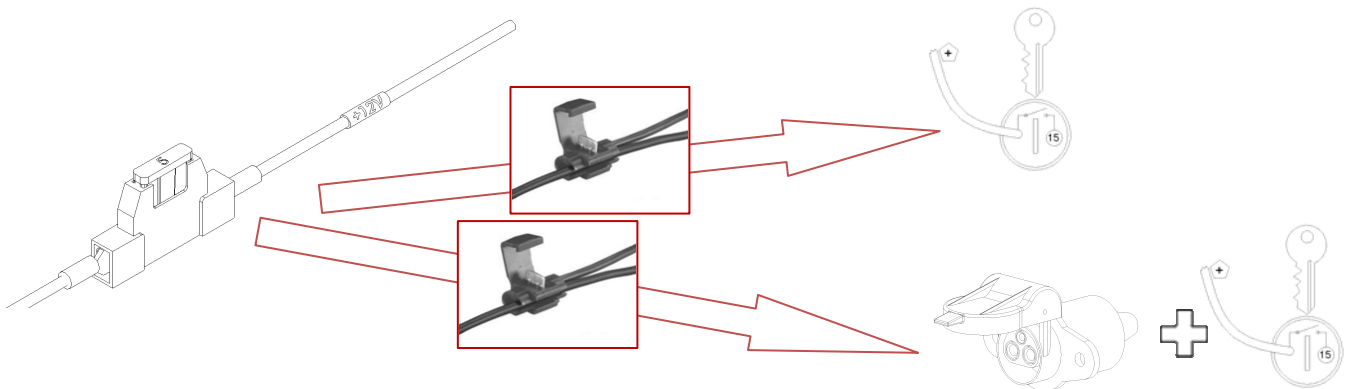

- Tractors without battery breaker: The cable with the 15 A fuse and the description "+12V" has to be connected to the +pole of the battery by means of the supplied cable shoe. The fuses should be positioned at a place which is easy accessible.
Tractors with battery breaker: The cable with the 15 A fuse and the name: "+12V" should be connected directly to the current supply socket according to DIN 9680 (3-pole socket)
If both options are not feasible, a cable should be found (possibly in the fuse box) which is able to provide the required amperage.

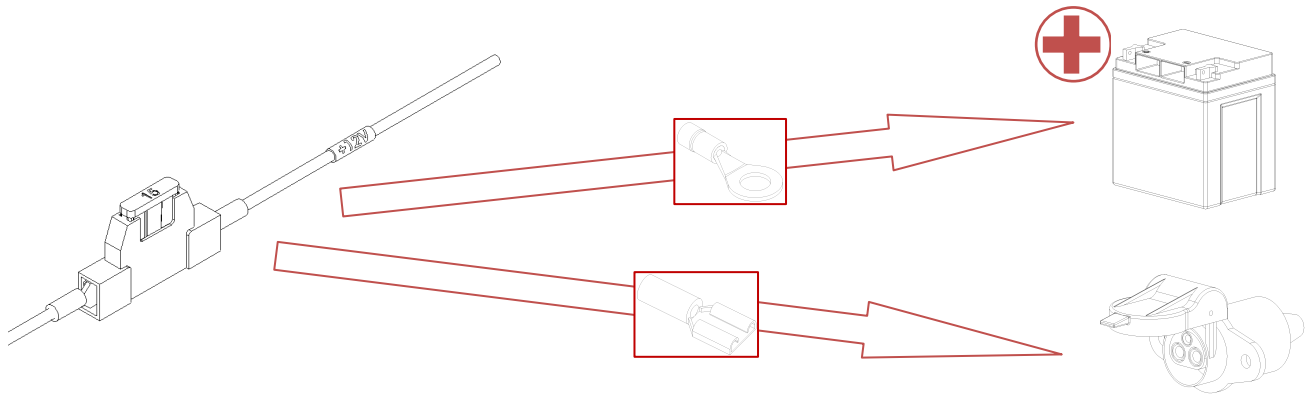

- Tractors without battery breaker: The black mass cable with the name "T" should be connected directly to the pole of the battery by means of the supplied cable shoes.
Tractors without battery breaker: The black mass cable with the name "T" should be connected directly to the current supply socket according to DIN 9680 (3-pole socket).
Should neither option be feasible, a cable or a circuit connection (perhaps in the fuse box) should be found, which ensures a save bonding.

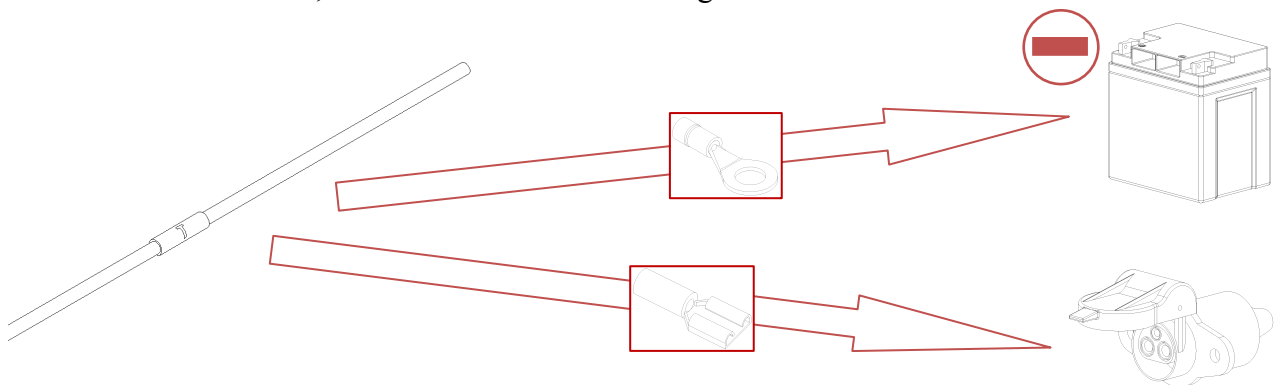

- The cable with the 3 plug bases (for options)
Switch buttons will be supplied with the electro-kit!
According to the version supplied, up to 3 additional press buttons will be required.

Robust F:

Robust FS / FZ:

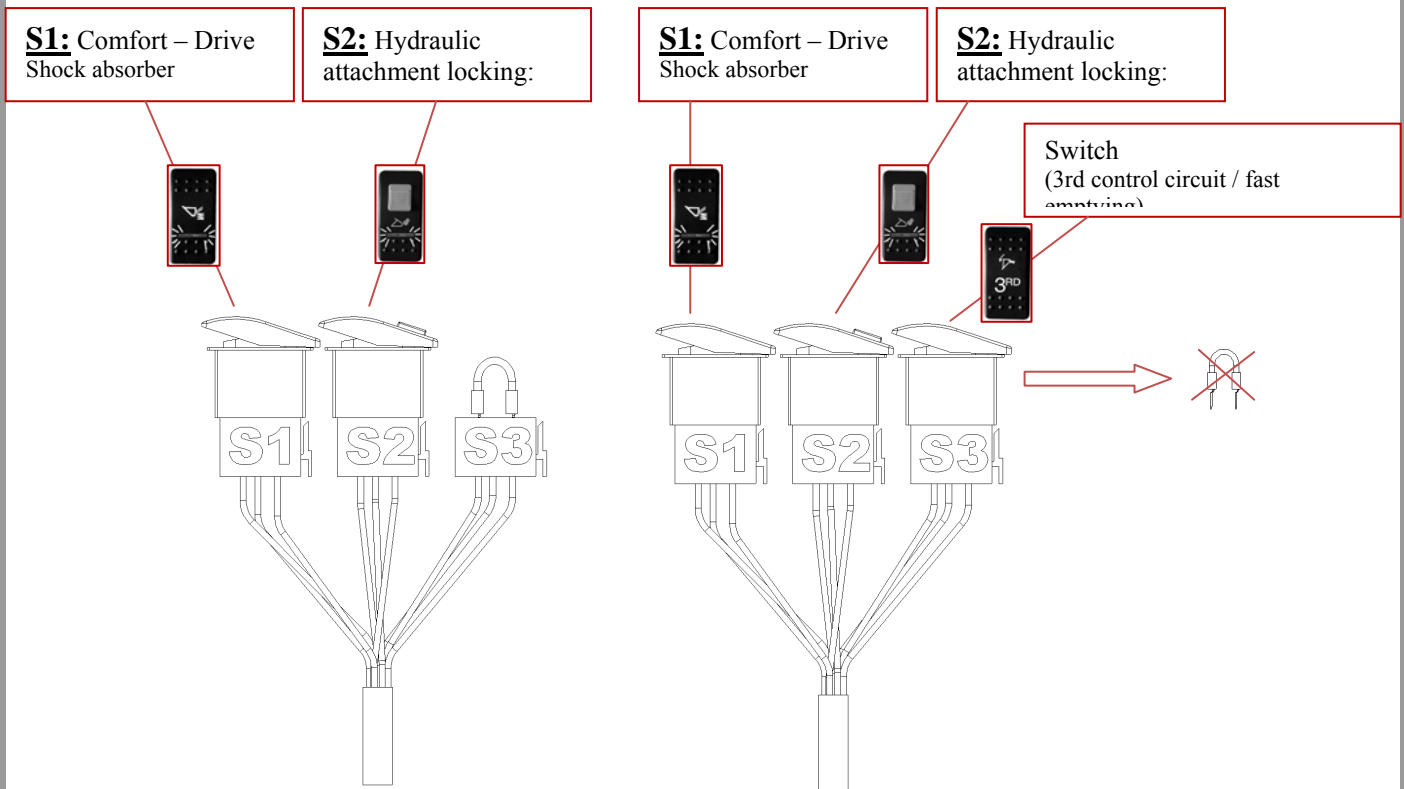

Opening for the press button: see mounting instruction for safety button
The cables are attached with the help of cable connectors.

joystick press buttons and socket cable plan

Robust F:

The assignment of keys to the socket outputs are described below and preinstalled.

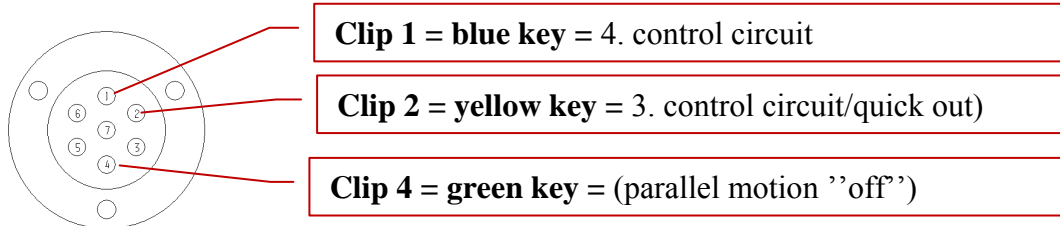

Key functions:

- Yellow key à quick out (HD, HDP) + 3. control circuit
- Green key à parallel motion "off" (HDP)
- Blue key (4th control circuit + (floating position)



Robust - FZ (not with RTL!) (recommendation fo lifting arms with 4th oil service)

The assignment of keys to the socket outputs are described below and preinstalled.
 At the Robust FZ in connection with 4th oil service you may interchange cable of clamp 1 and clamp 4 so that the 4th oil service may not activate the floating position unintendedly.

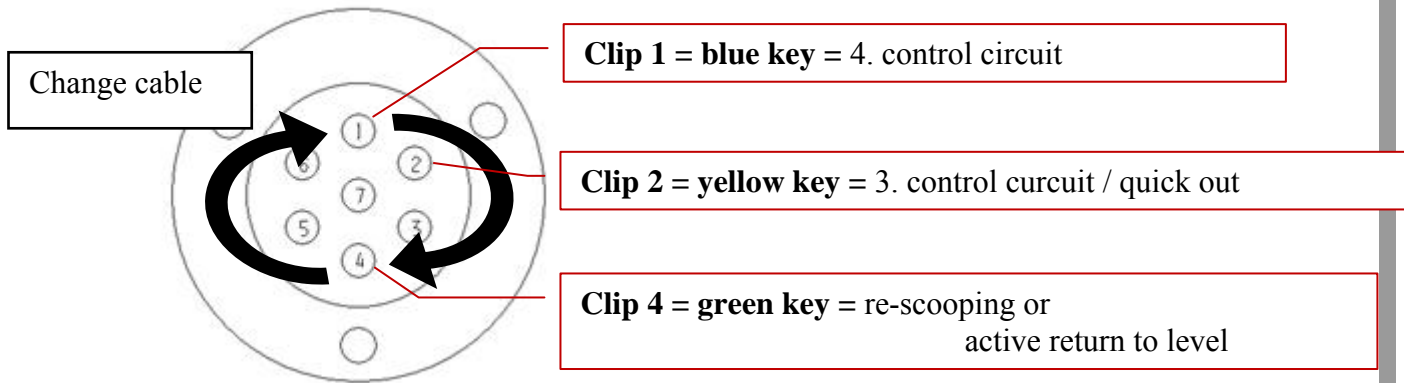

Key functions:

- Yellow key → 3. control circuit + quick out (FS+, FZ+)
- Green key → 4. control circuit
- BlaBlue key → re-scooping (FZ+) + (floating position)



Connection diode for Robust FS / FZ with 4th control circuit:

The diode is included in the electro-kit!

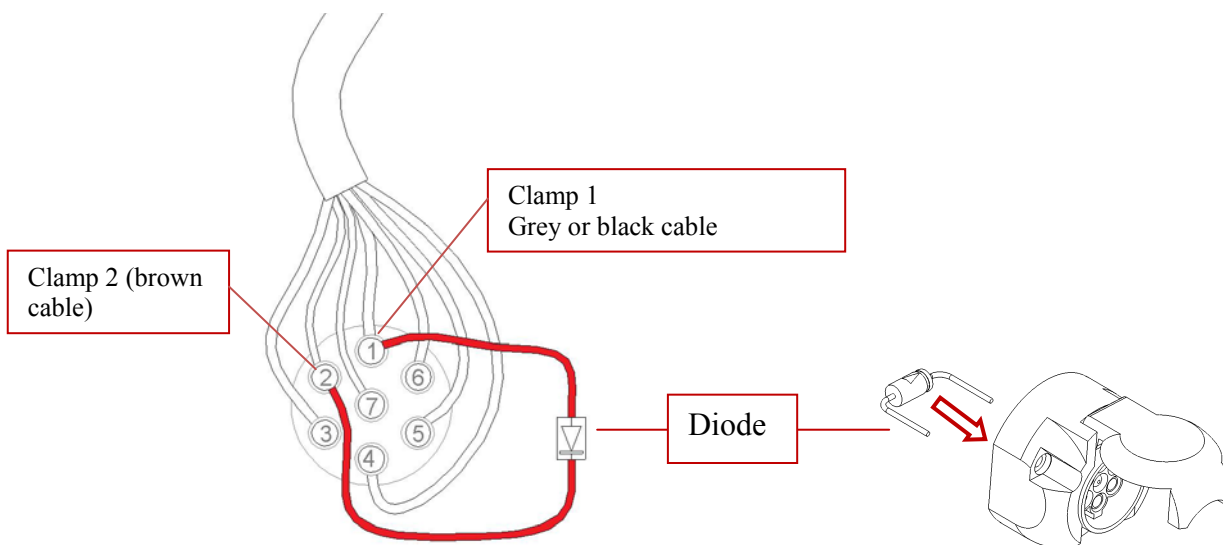

3. Basic settings:

Software version 3.5 (green point outside on the housing)

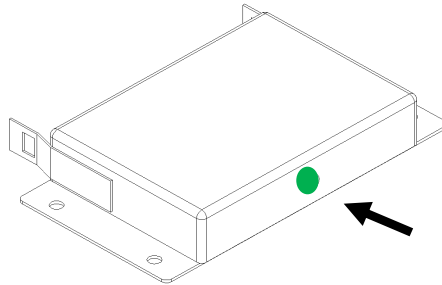

The basic settings are preset ex works.

This means that the calibration of the joystick and the selection of the valve must not be carried out any more.

However, you should check the type of control block programmed.

Calibration of the joystick:

The zero position and the maximum displacement of the joy stick always imply certain amounts of tolerances and have to be calibrated and after replacement of joystick or processor.

Working steps:

- Press and hold yellow and green button.
- Move joystick forward (direction of raise).
- Switch on power supply. The light-emitting diode in the safety button flashes quickly.
- The joystick has to be switched to all 4 blocks and back to the centre and needs to be held for 1 sec. Green and yellow press button need to be pressed.
- Release the joystick and the buttons. The zero position will be measured and saved after two seconds.

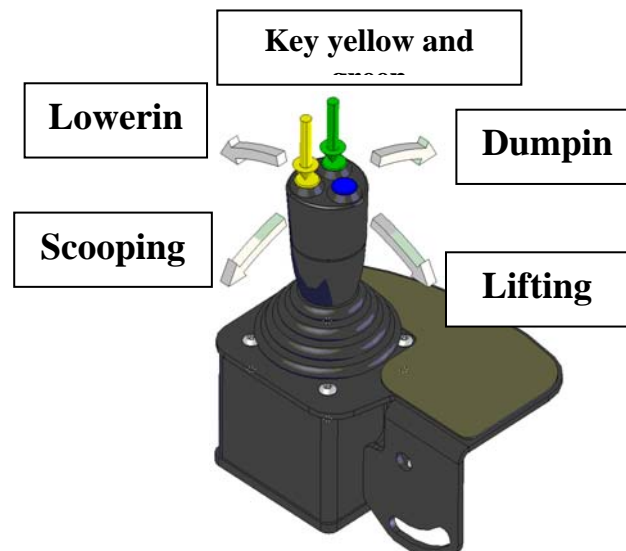

Set valve type:

Three piloting programmes exist for the three proportional valve types:

Working steps:

- Joystick in centre position and press one (two) key (s):

Yellow key (Progr. 1 for Walvoil LS (Nr.: 3349900) a. OC (Nr.: 1417930)

Green key à Progr. 2 for Nimco LS (Type: 100 36) a.. Nimco OC (Type: 1S-4899)

Blue key (Progr. 3 for Nimco LS for low standby pressure (Type: 10860-1S)

Green + blue key (Progr. 4 for Walvoil LS-LSP (Nr.: 1433100)

(For valve type see name plate or delivery note)

- Switch on power supply. The light-emitting diode in the safety button flashes quickly.
- Release key after 6 seconds. The controller is ready for operation.
- The valve type during activation is indicated by the first five flashing cycles.

1x short flash: Prog. 1

2x short flashes in succession Prog. 2

3x short flashes in succession Prog. 3

4x short flashes in succession Prog. 4

ECO - Proportional Valve

Operating instructions

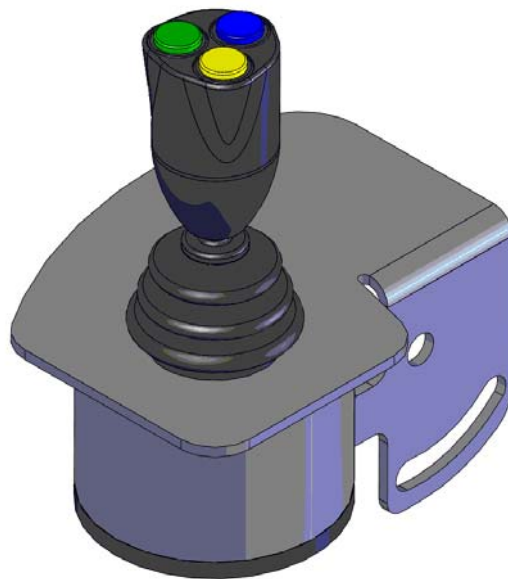

+



Operating instructions

Version 3.5

The controller is started via the ignition of the tractor remaining in stand-by mode. In this mode, displacement of the joystick is not followed by a reaction of the lifting arm. The light-emitting diode (LED) in the safety button is illuminated.

Shortly press the safety button to activate the controller. (The valve block activated is indicated by the five flashing cycles). The front loader is ready for use with the joystick now. Shortly press the safety button to reactivate the standby-mode of the controller (road operation lock).

Besides this mounting instruction you need to observe the general frontloader manuals P 1359, P 1360 P 1494 and P 1520 (according to the corresponding type of lifting arm)

Basic functions:

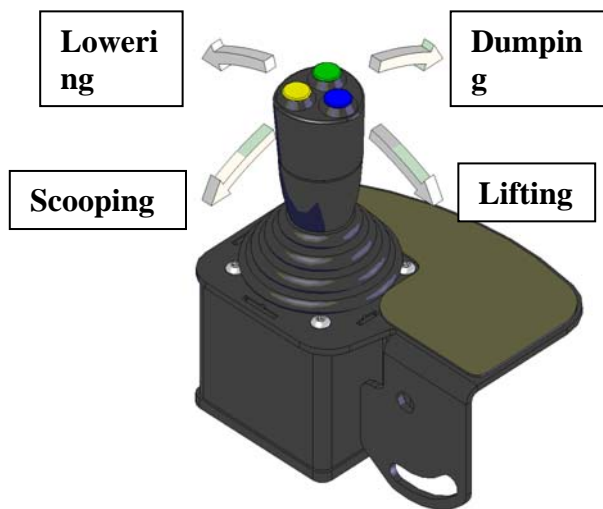

Additional functions:

- Quick out / fast emptying (FS_{quick out}/ FZ₊) (i. V. with scooping)

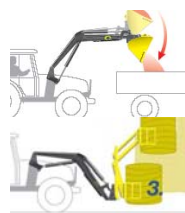

- 3. Control circuit (i. V. with scooping/dumping)

- 4. Control circuit (FS, FS+, FZ, FZ₊) (i. V. with scooping/dumping)
- or
- activ return to level (FZ_{RTL})



- Floating position (i. V. with lowering)
- 4. Control circuit (FZ_{RTL}) (i. V. with scooping/dumping)
- Re-scooping (FZ₊) (i. V. with lifting)

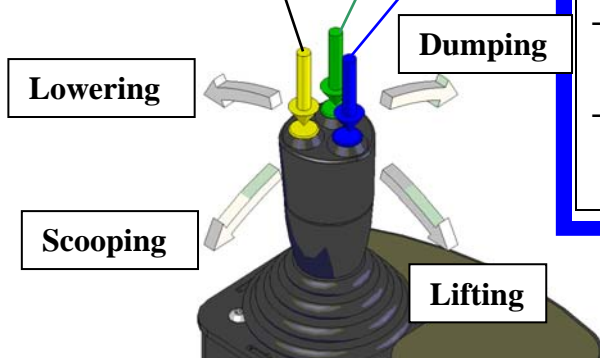

Maintenance notes:



Attention.

Before starting maintenance work, make sure you are wearing the personal protections (protective overalls, gloves, goggles, protective footwear, etc.).



GENERAL MAINTENANCE INSTRUCTIONS:

- Never perform maintenance with the front loader raised.
- Avoid carrying out maintenance operations if lighting is insufficient.
- Only carry out maintenance if the machine is at a temperature of below 55°C
- If normal maintenance of the tractor is to be performed, disconnect the loader so as to allow safe access to the parts to be checked, replaced or adjusted.
- Maintenance of the loader must be carried out when the loader is connected to the machine.
- Before performing maintenance operations on the loader, clean it carefully and, if necessary, wash the parts to be lubricated (greasing nipples); this applies above all when carrying out controls on the hydraulic circuit.
- Before inspecting the hydraulic equipment and connections, drain residual pressure completely.

Fault finding:

Fault finding only applies to the controller. The correct hydraulic connection of the valve is a precondition!

Problem:	Cause:	Solution:
Battery discharged.	Cable connected incorrectly.	Connect the brown cable with the name UZ according to the installation instructions.
The controller does not comprise a ready indication (LED is illuminated in the safety button)	Damaged fuse	Replace fuse. There are two different fuses (5A and 15 A)!
The controller cannot be switched from the standby mode to the working mode.	Joystick not calibrated.	Calibrate the joystick according to the instructions.
	The light-emitting diode in the safety button flashes quickly.	Damaged electrical harness. (Cable break)
		Operating voltage too high or too low (cable cross sections undersized).
Lifting arm not raised when displacing the joystick	Controller not in working mode.	Press safety button (see operating instructions)
	Valve type not set correctly.	Set valve type (see operating instructions)
	Circulation pressure in hydraulic system (OC-system) too low.	Displace joystick at a maximum of 30% and hold. The lifting arm should move after 5 sec. at the latest.
	Pressure in hydraulic system (LS system) too low < 14 bar.	Use an additional controller from the tractor in connection with the joystick. After this the pressure reservoir has to take over.
		Incorrect valve ⇒ Use proportional valve for LS system with low standby pressure. ⇒ After sales service
After each short working break no reaction → of the lifting arm when displacing the joystick.	Valve type not set correctly.	Set valve type (see operating instructions)
	Damaged valve pressure	Check the pressure reservoir.

	reservoir	(Membrane still connected to the threaded connection? ⇒ If not, replace pressure reservoir).
Tolerance too high at start or end point of displacement. Joystick has to be displaced too far until lifting arm/attachment moves or maximum speed of lifting arm/attachment is achieved before joystick is displaced in full.	Valve type not set correctly.	Set valve type (see operating instructions)
Malfunction of lifting arm/attachment Raise instead of lower etc.	Cable connected incorrectly to the valve block.	Connect cable correctly. (See installation instructions)
	Joystick installed the wrong way round	Install joystick correctly (see installation instructions)
Additional functions (3 control circuits etc.) do not work	7-pin socket not connected.	Connect 7-pin socket.
	Cable break	Check electrical harness of tractor and lifting arm. Please find the connection diagram in the instruction manual of the front loader.
	Grounding problems	Solve grounding problems with the corresponding solenoid on the cross tube.
HDP lifting arm does not lower in floating position?	Valve type not set correctly.	Set valve type (see operating instructions)
	Toggle bolt on the valve block completely closed.	Turn toggle bolt twice.

Service-LED's:

